

| 1 | 2 | 3 | 4 | 5 | | | | |
|-----|------|----------|--------------|------|------|------|--------|--------|
| No. | NAME | MATERIAL | DWG/MATL No. | CODE | Q'TY | SIZE | WEIGHT | REMARK |
| | | | | | 0 | | | |

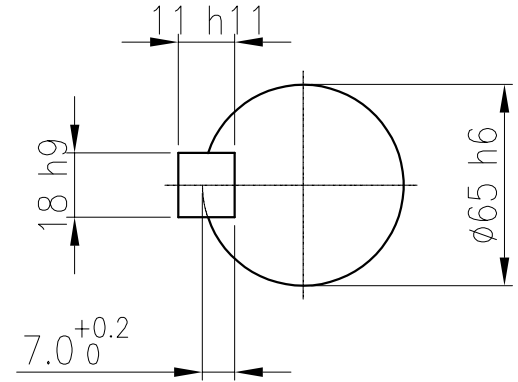

OUTPUT SHAFT
KEY 18 x 11 x 54

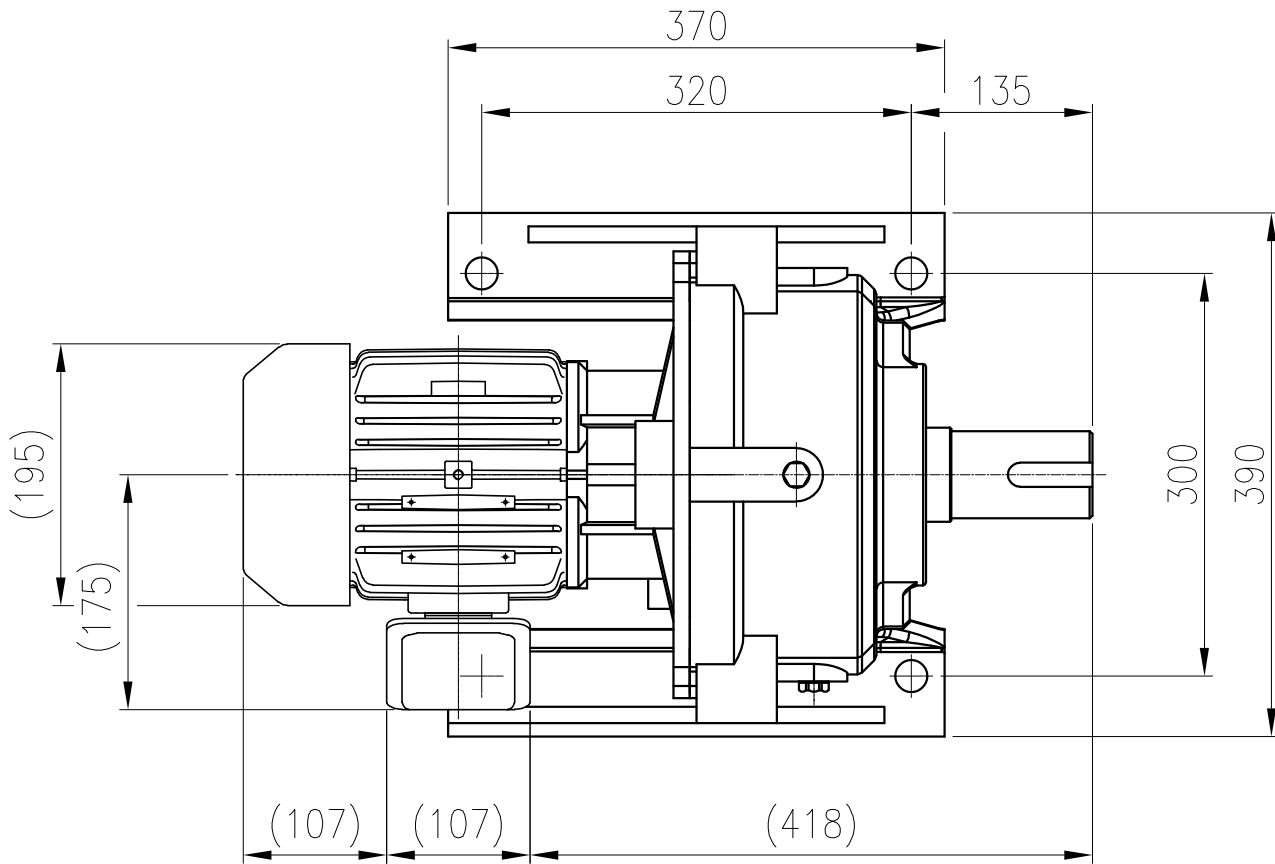
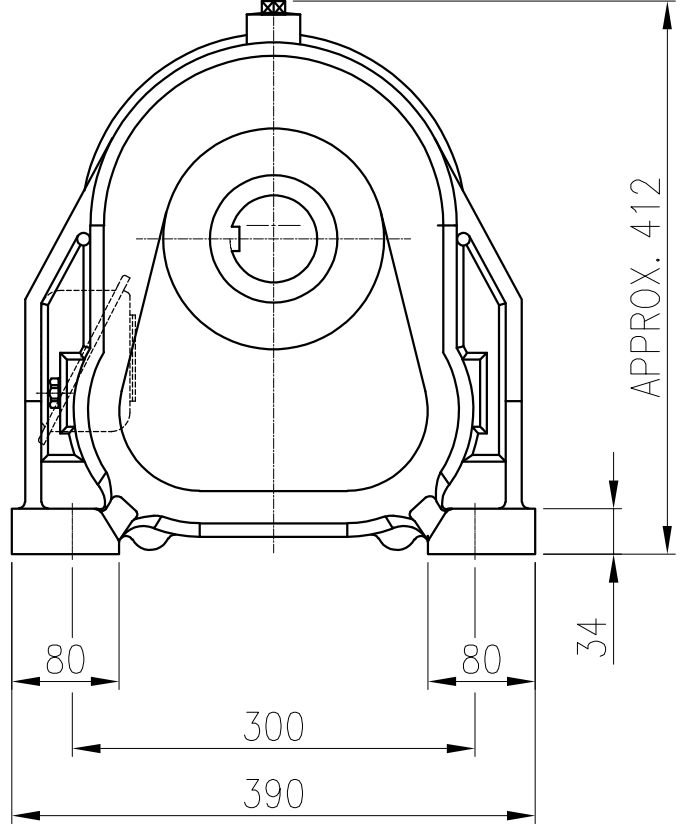
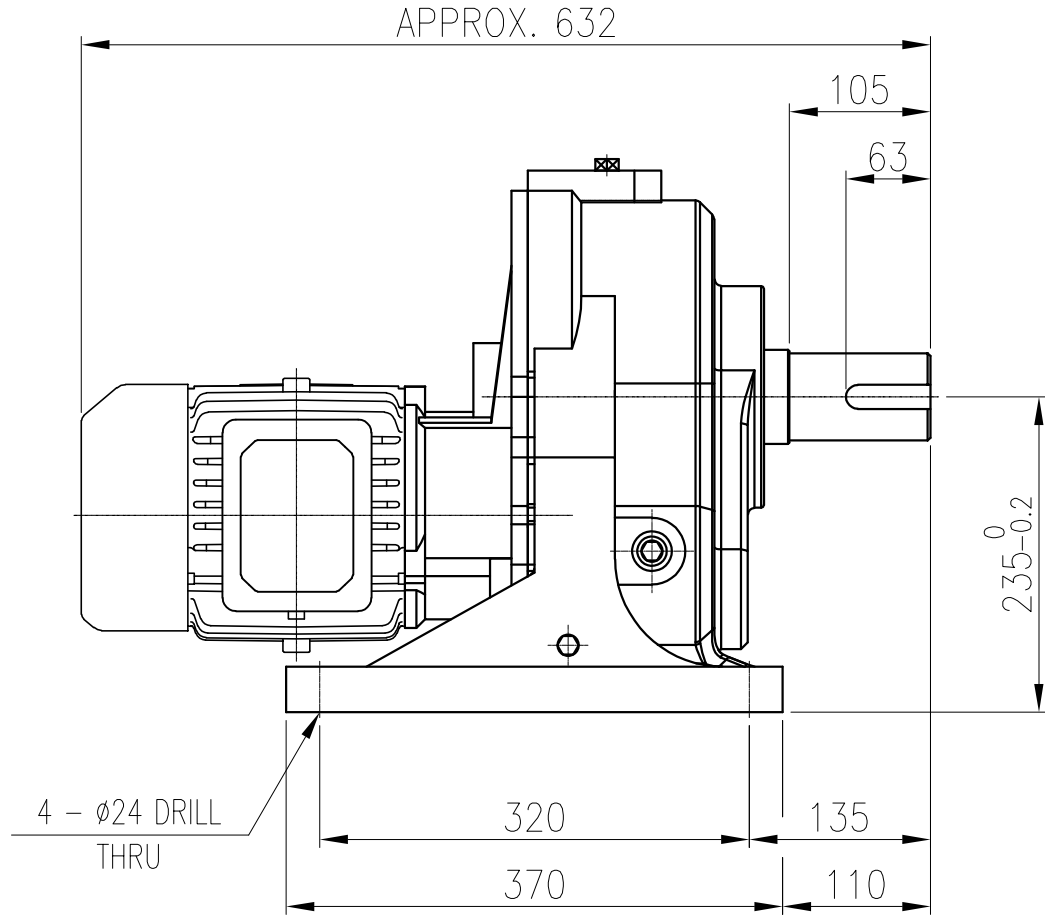

| | | | | | |
|--------------|-------------------|--------------|--------|--------|---------------------|
| | | BEARING | | | |
| OIL SEAL | | 2ND PINION | 6204ZZ | 6205ZZ | GREASE : NLGI(EP)00 |
| MOTOR SHAFT | D(M) 25 x 38 x 8 | 3RD PINION | 6207ZZ | 6309ZZ | ABOUT 2.04 kg |
| OUTPUT SHAFT | D(M) 70 x 95 x 13 | OUTPUT SHAFT | PM5060 | 22214 | WEIGHT 117.88 kg |

DWG NAME **외형도**
OUTLINE DIMENSION

| | | | |
|---------|----------------|-------|-----|
| DWG No. | EK2D007674H001 | UNIT | mm |
| | | SCALE | 1:1 |

| | | | | | |
|------------|------------|------------|------------|------------------------|------------|
| DESIGNED | CHECKED | REVIEWED | APPROVED | DATE | 2019-01-21 |
| 2019.01.21 | 2019.01.21 | 2019.01.21 | 2019.01.21 | REVISION No. | 00 |
| 하슬기 | 문병선 | 박희성 | 최성민 | THIRD ANGLE PROJECTION | |

| No. | DATE | DESCRIPTION of REVISION |
|---------------------------------|------|-------------------------|
| | | |
| TYPE 23Fr(1.5kW)_100~120:1_프리미엄 | | |

| | | |
|----------|---|-----|
| REF. No. | - | (A) |
|----------|---|-----|

이 도면상에 표시된 정보는 호성중공업(주)의 소유이며 당사의 사전 서면동의 없이 무단사용을 금합니다.